



PEC Montageschienen

Europäisch Technische Bewertung
ETA-21/0695



PEC Montageschienen

Allgemeine Hinweise

Diese Europäische Technische Bewertung gilt nur für Original-Produkte, die von Hilti mit den in diesem Dokument beschriebenen Spezifikationen hergestellt wurden. Es liegt in der Verantwortung des Anwenders, die Eignung eines Produkts für die spezifische Anwendung zu überprüfen

**European Technical
Assessment****ETA-21/0695
of 06/08/2021***English translation prepared by CSTB - Original version in French language***General Part**

Trade name:	PEC-M Mounting channel
Product family:	Mounting channel
Manufacturer:	PEC Europe Obere Kaiserwerther Straße 56 47249 Duisburg Deutschland
Manufacturing plants:	Hilti Werke
This European Technical Assessment contains:	20 pages including 17 pages of annexes which form an integral part of this assessment
This European Technical Assessment is issued in accordance with Regulation (EU) No 305/2011, on the basis of:	European Assessment Document (EAD) EAD 33-0667-01-0602
This version replaces:	-

Translations of this European Technical Assessment in other languages shall fully correspond to the original issued document and should be identified as such. Communication of this European Technical Assessment, including transmission by electronic means, shall be in full. However, partial reproduction may be made, with the written consent of the issuing Technical Assessment Body. Any partial reproduction has to be identified as such.

Specific Part

1 Technical description of the product

The PEC-M mounting channel is a system consisting of C-shaped channel profile made of carbon steel or stainless steel as well as a special shape HBC channel bolts.

The mounting channel can be welded to the steel structure or it can be attached to a concrete substructure via post installed fasteners. Any fixture may be connected to the mounting channel by the HBC channel bolts with appropriate nuts and washers.

The product description is given in Annex A.

2 Specification of the intended use

The performances given in Section 3 are only valid if the mounting channel is used in compliance with the specifications and conditions given in Annex B.

The verifications and assessment methods on which this European Technical Assessment is based lead to the assumption of a working life of the mounting channel of at least 50 years. The indications given on the working life cannot be interpreted as a guarantee given by the producer, but are to be regarded only as a means for choosing the right products in relation to the expected economically reasonable working life of the works.

3 Performance of the product and references to the methods used for its assessment

3.1 Mechanical resistance and stability (BWR 1)

Essential characteristic	Performance
Characteristic resistances of under static and quasi static load and displacement	See Annex C1 to C5
Characteristic resistances under fatigue cyclic load	No performance assessed

3.2 Safety in case of fire (BWR 2)

Essential characteristic	Performance
Reaction to fire	Class A1
Characteristic resistance to fire	No performance assessed

3.3 Hygiene, health and the environment (BWR 3)

Regarding dangerous substances contained in this European technical approval, there may be requirements applicable to the products falling within its scope (e.g. transposed European legislation and national laws, regulations and administrative provisions). In order to meet the provisions of the Construction Products Directive, these requirements need also to be complied with, when and where they apply.

3.4 Safety in use (BWR 4)

For Basic requirement Safety in use the same criteria are valid as for Basic Requirement Mechanical resistance and stability.

3.5 Protection against noise (BWR 5)

Not relevant.

3.6 Energy economy and heat retention (BWR 6)

Not relevant.

3.7 Sustainable use of natural resources (BWR 7)

For the sustainable use of natural resources no performance was determined for this product.

3.8 General aspects relating to fitness for use

Durability and Serviceability are only ensured if the specifications of intended use according to Annex B1 are kept.

4 Assessment and verification of constancy of performance (AVCP) system applied, with reference to its legal base

In accordance with EAD No. EAD 33-0667-01-0602, the applicable European legal act is: 1998/214/EC.

The system to be applied is: 2+.

5 Technical details necessary for the implementation of the AVCP system, as provided for in the applicable EAD

Technical details necessary for the implementation of the Assessment and verification of constancy of performance (AVCP) system are laid down in the control plan deposited at Centre Scientifique et Technique du Bâtiment.

The manufacturer shall, on the basis of a contract, involve a notified body approved in the field of mounting channels for issuing the certificate of conformity CE based on the control plan.

The original French version is signed by

Anca Cronopol

Product and installation condition

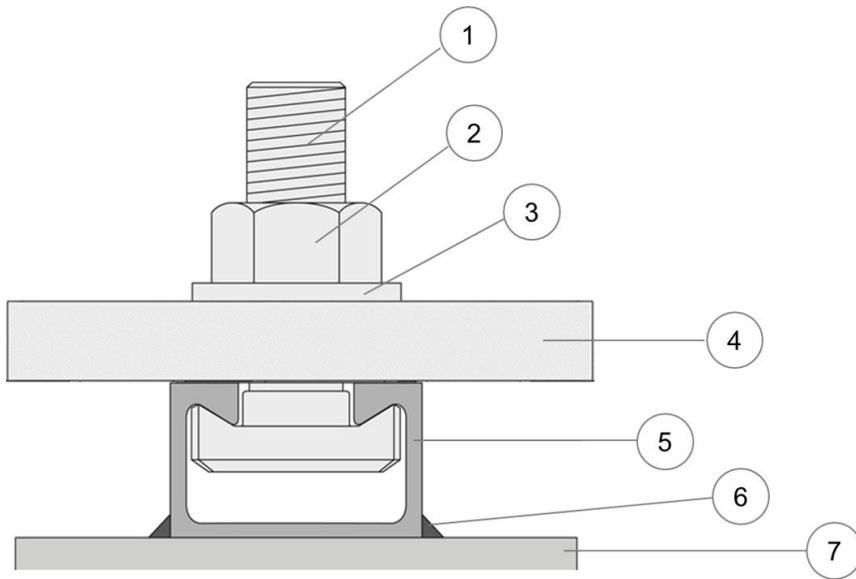

Key

- 1 channel bolt
- 2 hexagonal nut
- 3 washer
- 4 fixture
- 5 channel profile
- 6 weld
- 7 base material

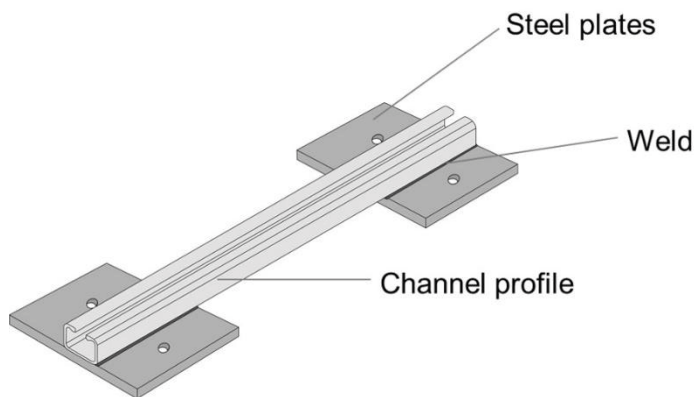
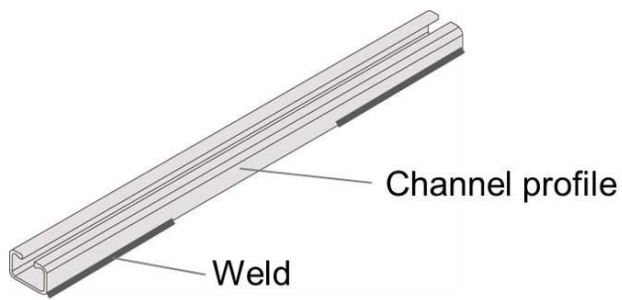

Mounting channels (PEC-M) with channel bolts (HBC)

Product Description
Installed condition

Annex A1

Installation types

Fillet-welded mounting channels

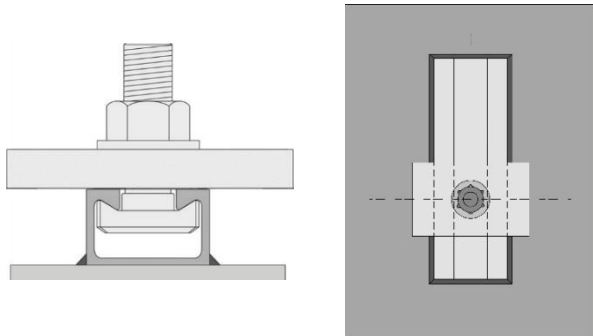

Cross section

Top view

Post-installed mounting channels

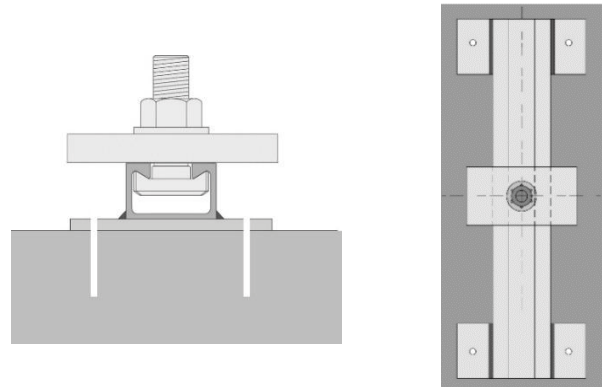

Cross section

Top view

Marking of the mounting channels:

PEC-M(Z) X (PI) Z

- PEC-M = Identifying mark of the manufacturer
- Z = Additional marking for serrated channels
- X = Size of the channel
- PI = Additional marking for post-installed
- Z = Corrosion class / Material
 - B = Blank channel
 - F = Hot-dip galvanized
 - A4 = Stainless steel

PEC-M 40/22 F

(e.g. PEC-M 40/22 F)

40/22 = Mounting channel size 40/22

F = Hot-dip galvanized

Marking of the channel bolt:

HBC-(T)X(-N) YZ

- HBC = Identifying mark of the manufacturer
- T = Additional marking for serrated bolt
- X = Channel bolt
- N = Additional marking for notching bolt
- Y = Steel grade (4.6, 8.8, 70)
- Z = Corrosion class / Material
 - F = Hot-dip galvanized
 - R = Stainless steel

**HBC-40
8.8F**

(e.g. HBC-40/22 8.8F)

40 = Channel bolt in combination with PEC-M 40/22F

8.8 = Steel grade

F = Hot-dip galvanized

Mounting channels (PEC-M) with channel bolts (HBC)

Product Description
 Installation types and marking

Annex A2

Channel profiles

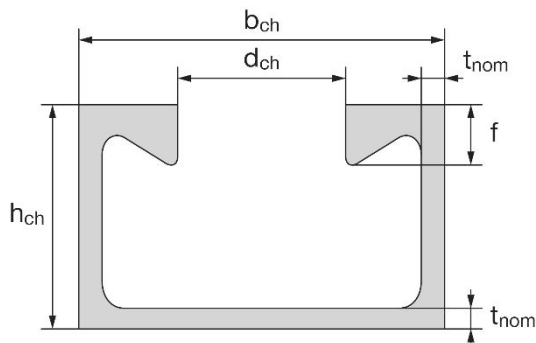

PEC-MZ 29/20, PEC-M 40/22, PEC-M 50/30, PEC-M 52/34

Table 1: Dimensions of channel profile

Mounting channel	b_{ch}	h_{ch}	t_{nom}	d_{ch}	f	I_y
	[mm]					[mm ⁴]
PEC-MZ 29/20	29,0	20,0	2,5	14,0	5,0	10056
PEC-M 40/22	40,1	23,0	2,7	18,0	6,0	21504
PEC-M 50/30	49,6	30,0	3,2	22,5	8,1	57781
PEC-M 52/34	52,5	34,0	4,0	22,5	11,5	97606

Mounting channels (PEC-M) with channel bolts (HBC)

Product Description

Channel profiles

Annex A3

Channel bolts

Table 2: Dimensions of channel bolt

Appropriate mounting channel	Channel bolt	Dimensions			
		b ₁	b ₂	k	d
		[mm]			
PEC-MZ 29/20	HBC-T 29/20	13,5	23,0	8,0	12
PEC-M 40/22	HBC-40/22	14,0	33,0	10,5	10
		17,0		11,5	16
PEC-M 40/22	HBC-40/22-N	17,0	33,0	11,5	16
PEC-M 50/30 PEC-M 52/34	HBC-50/30	17,0	42,0	14,5	12
		21,0		15,5	20
PEC-M 50/30 PEC-M 52/34	HBC-50/30-N	21,0	42,0	15,5	16 20

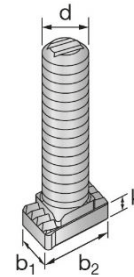

HBC-T 29/20

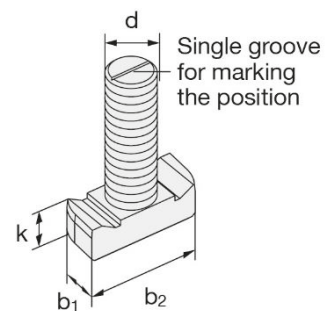

HBC-40/22, HBC-50/30

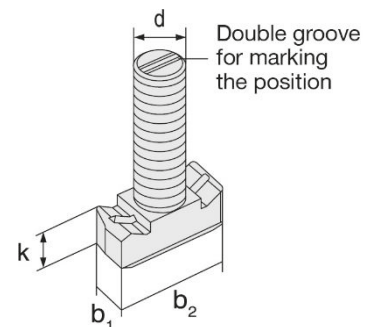

HBC-40/22-N, HBC-50/30-N

Table 3: Steel grade and corrosion class

Channel Bolt	Carbon steel ¹⁾		Stainless steel ¹⁾
	4.6	8.8	
Steel grade	4.6	8.8	A4-70
f _{uk} [N/mm ²]	400	800 / 830 ²⁾	700
f _{yk} [N/mm ²]	240	640 / 660 ²⁾	450
Corrosion class	G ³⁾ F ⁴⁾		R ⁵⁾

¹⁾ Material properties according to Annex A6

²⁾ Material properties according to EN ISO 898-1: 2013

³⁾ Electroplated

⁴⁾ Hot-dip galvanized

⁵⁾ Stainless steel

Mounting channels (PEC-M) with channel bolts (HBC)

Product Description

Channel bolts (HBC)

Annex A4

Table 4: Materials

Component	Carbon steel				Stainless steel
	Mechanical properties	Coating			Mechanical properties
1	2a	2b	2c	2d	3
Channel Profile	1.0038, 1.0044, 1.0045 according to EN 10025: 2005 1.0976, 1.0979 according to EN 10149: 2013	No coating	Hot dip galvanized $\geq 50 \mu\text{m}$ according to EN ISO 10684: 2004/AC: 2009		1.4362, 1.4401 1.4404, 1.4571, 1.4578 according to EN 10088: 2005
Channel bolt	Steel grade 4.6 and 8.8 according to EN ISO 898-1: 2013	Electroplated according to EN ISO 4042: 1999	Hot dip galvanized $\geq 50 \mu\text{m}$ according to EN ISO 10684: 2004/AC: 2009		Grade 50 or 70 according to EN ISO 3506: 2009
Plain washer ¹⁾ according to ISO 7089: 2000 and ISO 7093-1: 2000	Hardness class $A \geq 200 \text{ HV}$	Electroplated according to EN ISO 4042: 1999	Hot dip galvanized $\geq 50 \mu\text{m}$ according to EN ISO 10684: 2004/AC: 2009		1.4401, 1.4404 1.4571, 1.4578 according to EN 10088: 2005
Hexagonal nut according to ISO 4032: 2012 or DIN 934: 1987-10 ²⁾	Property class 5 or 8 according to EN ISO 898-2: 2012	Electroplated according to EN ISO 4042: 1999	Hot dip galvanized $\geq 50 \mu\text{m}$ according to EN ISO 10684: 2004/AC: 2009		Property class 50, 70 or 80 according to EN ISO 3506: 2009

¹⁾ In scope of delivery only for notched bolts

²⁾ Hexagonal nuts according to DIN 934: 1987-10 for channel bolts made from carbon steel (4.6) and stainless steel

Mounting channels (PEC-M) with channel bolts (HBC)

Product Description
Materials

Annex A5

Specifications of intended use

Mounting channels and channel bolts subject to:

- Static and quasi-static loads in tension, shear perpendicular to the longitudinal axis of the channel and shear in the direction of the longitudinal axis.
- Shear load with and without lever arm

Intended use:

- In the case of steel structures, the channels are fillet welded (fully or partially) to the steel substructure.
- In the case of concrete substructures, the channel is fillet welded to steel plates which are then attached to the substructure via post-installed anchors or other means.

Use conditions (Environmental conditions):

- Structures subject to dry internal conditions (Mounting channels and channel bolts according to Annex A5, Table 4, column 2 and 3).
- Structures subject to internal conditions with usual humidity (e.g. kitchen, bath and laundry in residential buildings, exceptional permanent damp conditions and application under water) (Mounting channels and channel bolts according to Annex A5, Table 4, column 2c and 3).
- According to EN 1993-1-4: 2006 + A2: 2015 relating to corrosion resistance class CRC III (Mounting channels, channel bolts according to Annex A5, Table 4, column 3)

Design:

- Mounting channels are designed under the responsibility of an engineer experienced in anchorages and steel design.
- The welds are designed in accordance to EN 1993-1-8. In case of partially welded mounting channels, the maximum distance between the welds should not exceed the values given in Table 5, Annex B3
- For static and quasi-static loading the Mounting channels are designed in accordance with EOTA TR 076 "Design of Mounting channels", December 2020 and EN 1993-1

Installation:

- The installation of mounting channels is carried out by appropriately qualified personnel under the supervision of the person responsible for the technical matters on site.
- Use of the Mounting channels only as supplied by the manufacturer - without any manipulations, repositioning or exchanging of channel components.
- Cutting of the Mounting channels is allowed as long as the length of the minimum utilized piece is larger than the minimum welding length according to Annex B2, Table 5.
- In case of stainless-steel mounting channels, no corrosion protection is required after cutting as long as the cutting process has been done appropriately and contact with corrosion causing materials has been prevented.
- Blank mounting channels should be corrosion protected as required depending on the environmental conditions
- Installation in accordance with the manufacturer's specifications given in Annexes B4, B5, B6 and B7
- Washer may be chosen according to Annex A5 and provided separately by the user.
- Orientating the channel bolt (groove according to Annex B5 and Annex B6) perpendicular to the channel axis.
- The required installation torques given in Annexes B5, B6 and B7 must be applied and must not be exceeded.

Transportation and Storage:

- Store the channels at dry conditions, particularly in case of blank, carbon steel mounting channels

Mounting channels (PEC-M) with channel bolts (HBC)

Intended Use
Specifications

Annex B1

Table 5: Installation parameters for mounting channels

Mounting channel		PEC-MZ 29/20	PEC-M 40/22	PEC-M 50/30	PEC-M 52/34
Maximum spacing between welds	s_{max}	250			
End spacing for load application	x_{min}	25			35
Minimum channel length	$l_{ch,min}$	70	100		
Minimum welding length	$l_{w,min}$	70	100		

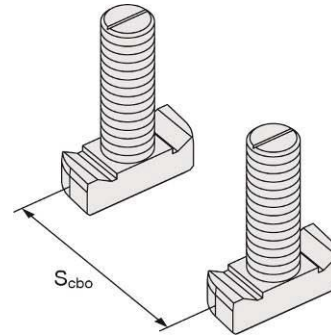
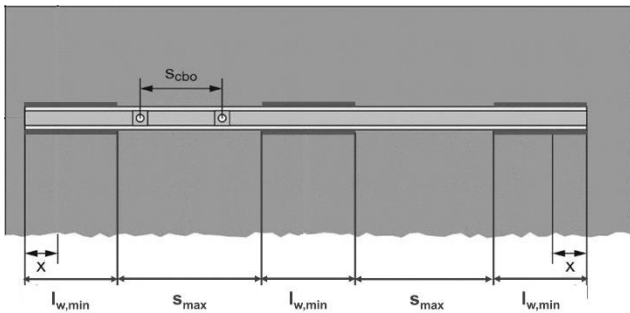

Table 6: Minimum spacing for channel bolts

Channel bolt			M10	M12	M16	M20
Minimum spacing between channel bolts	$s_{cbo,min}$	[mm]	50	60	80	100

s_{cbo} = spacing between channel bolts

Mounting channels (PEC-M) with channel bolts (HBC)

Intended Use

Installation parameters for Mounting channels (PEC-M)

Annex B2

Table 7: Required installation torque T_{inst}

Channel bolt		$T_{inst}^{1)}$ [Nm]						
		$T_{inst,g}$			$T_{inst,s}$			
		4.6	8.8	A4-70	4.6	8.8	A4-70	
HBC-29/20-T	M12	40		2)	2)	80	2)	
HBC-40/22	M10	15			2)	13	2)	22
	M12	25				45	50	
	M16	30				100	90	
HBC-40/22-N	M16	110	160	2)	2)	160	2)	
HBC-50/30	M12	25				45	50	
	M16	55				100	130	
	M20	55				360	250	
HBC-50/30-N	M16	110	185	2)		185	2)	
	M20	220	320	2)	320			

1) T_{inst} must not be exceeded

2) Product not available

Nota :

$T_{inst,g}$: General case – gap between mounting rail and the fixture

$T_{inst,s}$: Steel to steel contact

Mounting channels (PEC-M) with channel bolts (HBC)

Intended Use

Installation parameters for channel bolts (HBC)

Annex B3

pec EUROPE
 The best of
 both worlds!

PEC-M(Z)

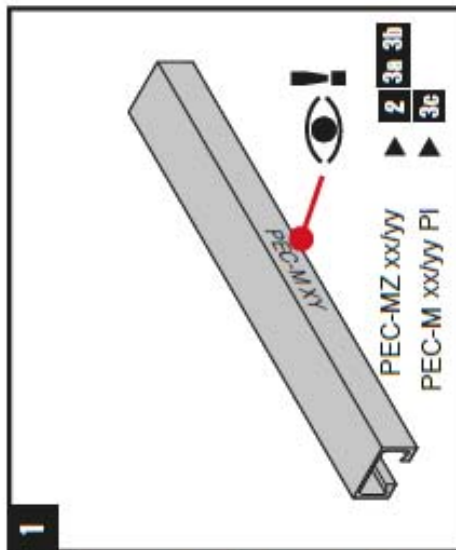
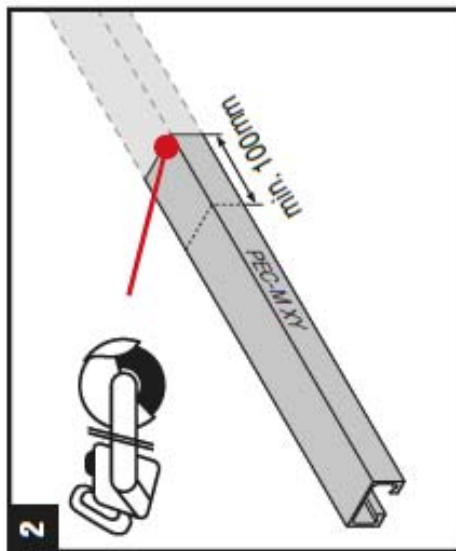

CE
 21
 PEC Europe
 Germany Duisburg
 Hilti Werke
 2451-CPR-EAD-2021.0001.001
 ETA-21/0695
 Notified body 2451
 EAD 330667-01-0602
 www.hilti.group

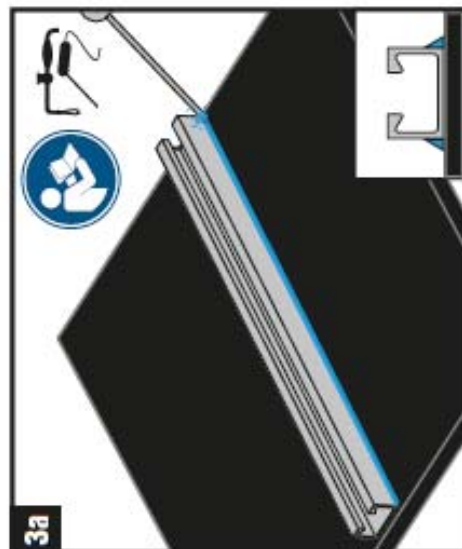
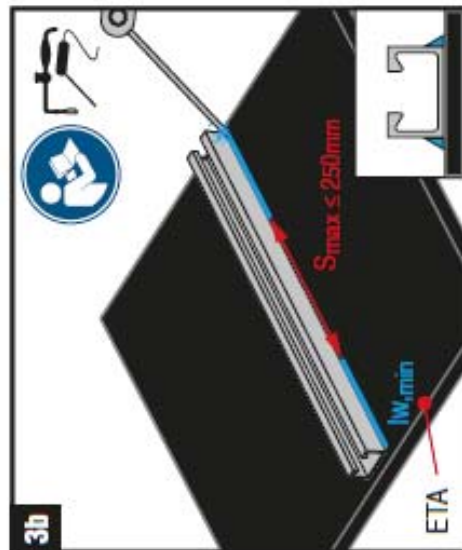
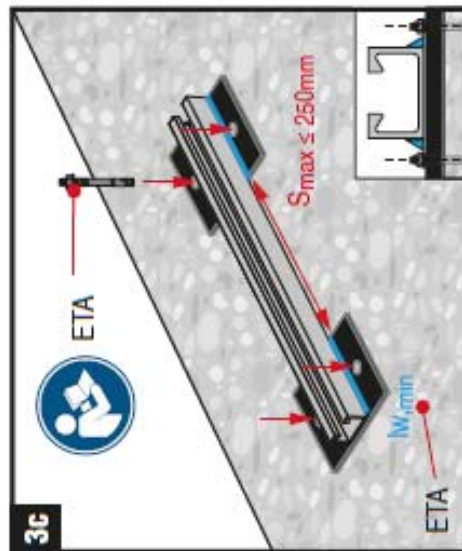

Mounting channels (PEC-M) with channel bolts (HBC)

Intended Use

Installation instructions for Mounting channels (PEC-M)

Annex B4



	HBC-40/22	PEC-M 40/22
	HBC-50/30	PEC-M 50/30, PEC-M 50/34

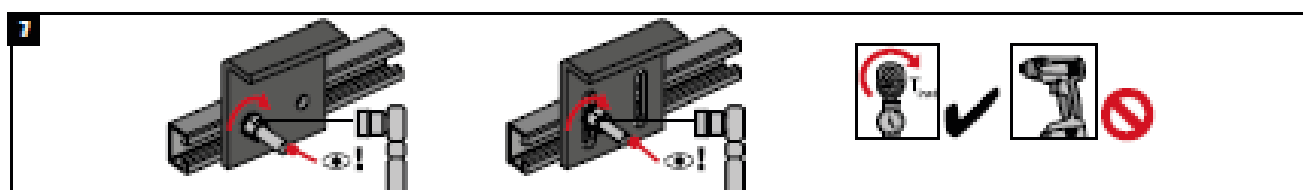
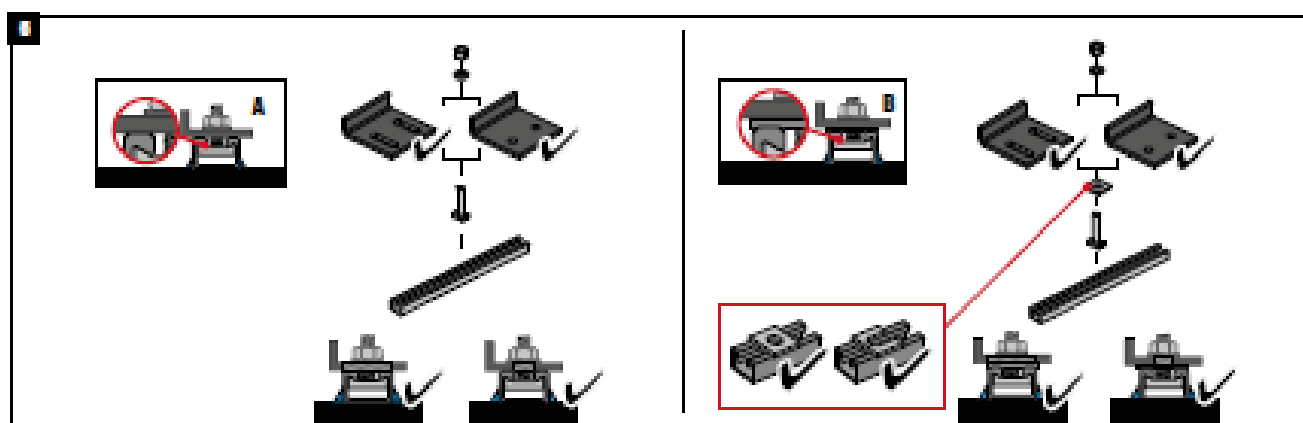
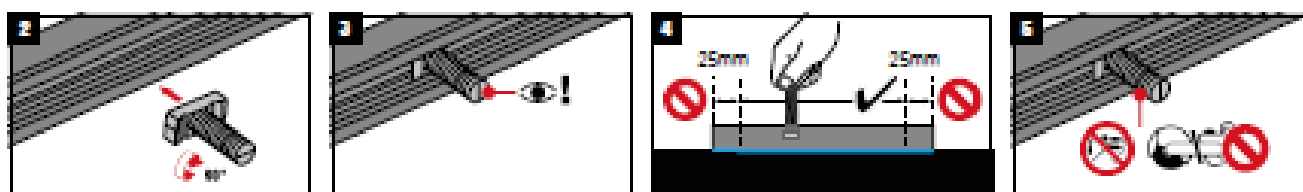

Channel bolt		T _{inst} [Nm]			
		 4.8, 8.8, A4-70	4.8	 8.8	A4-70
HBC-40/22	M10	15	13	15	22
	M12	25		45	50
	M16	30		100	90
HBC-50/30	M12	25	-	45	50
	M16	55		100	130
	M20	55		360	250

Mounting channels (PEC-M) with channel bolts (HBC)

Intended Use

Installation instructions for Mounting channels (PEC-M)

Annex B5



HBC-N

	HBC-40/22-N	PEC-M 40/22
	HBC-50/30-N	PEC-M 50/30, PEC-M 52/34

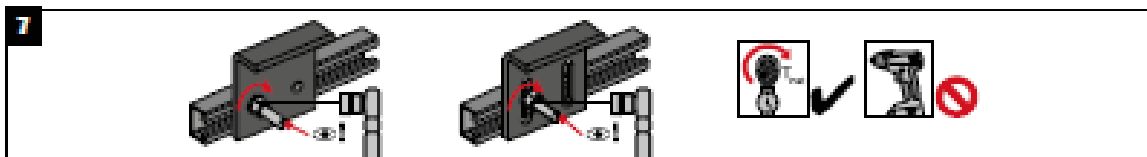
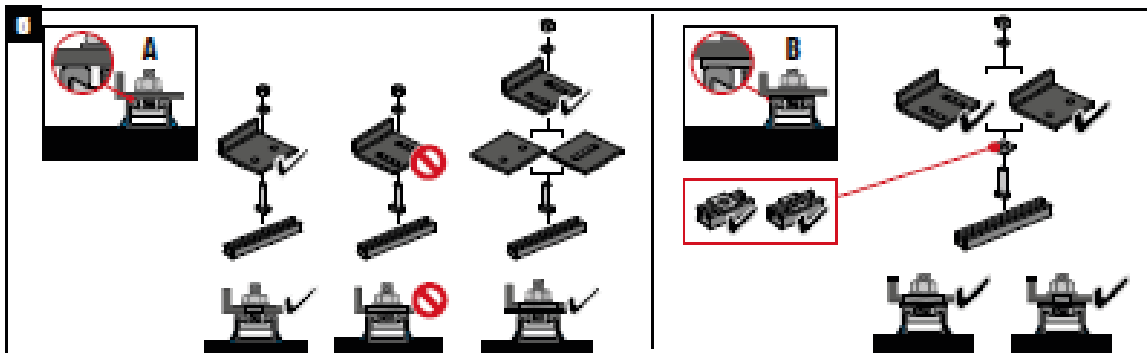

Mounting Channel	Channel Bolt	T _{max} [Nm]	
		A	B
		8.8	
PEC-M 40/22	HBC-40/22-N M16	160	
PEC-M 50/30, PEC-M 52/34	HBC-50/30-N M16	185	
PEC-M 50/30, PEC-M 52/34	HBC-50/30-N M20	320	

Mounting channels (PEC-M) with channel bolts (HBC)

Intended Use

Installation instructions for Mounting channels (PEC-M)

Annex B6



HBC-T-29/20

1

HBC-T-29/20	PEC-MZ 29/20

2

3

4

5

6

		T_{inst} [Nm]
Channel bolt		
HBC-T-29/20	M12	80

Mounting channels (PEC-M) with channel bolts (HBC)

Intended Use
 Installation instructions for Mounting channels (PEC-M)

Annex B7

Table 8: Characteristic resistances under tension load – steel failure of mounting channels

Mounting channel			PEC-MZ 29/20	PEC-M 40/22	PEC-M 50/30		PEC-M 52/34	
			M12	M16	M16	M20	M16	M20
Steel failure of channel lips								
Characteristic resistance	$N^{0_{Rk,s,l}}$	[kN]	25,8	36,2	55,8		87,0	
Characteristic spacing of the channel bolts for $N^{0_{Rk,s,l}}$	$s_{l,N}$	[mm]	58,0	80,2	99,2		105,0	
Partial factor	$\gamma_{Ms,l}^{1)}$	[-]	1,8					
Steel failure by bending of the channel								
Characteristic bending resistance of channel	M_{pl}	[Nm]	417	868	1724		2627	
Partial factor	$\gamma_{Ms,flex}^{1)}$	[-]	1,15					

¹⁾ In absence of other national regulations

Table 9: Displacements of mounting channels under tension load

Mounting channel			PEC-MZ 29/20	PEC-M 40/22	PEC-M 50/30	PEC-M 52/34
Tension load	N	[kN]	9,3	13,3	22,1	34,5
Short-term displacement ¹⁾	δ_{N0}	[mm]	0,6	0,9	1,0	1,4
Long-term displacement ¹⁾	$\delta_{N\infty}$	[mm]	1,3	1,7	2,1	2,9

¹⁾ Displacements in midspan of the Mounting channel, including slip of channel bolt, deformation of channel lips and bending of the channel

Mounting channels (PEC-M) with channel bolts (HBC)

Performance Data

Characteristic resistances and displacements of mounting channels under tension load

Annex C1

Table 10: Characteristic resistances under shear load – steel failure of mounting channel

Mounting channel			PEC-MZ 29/20	PEC-M 40/22	PEC-M 50/30	PEC-M 52/34
Steel failure: Local flexure of channel lips under shear load perpendicular to the longitudinal axis of the channel						
Characteristic resistance	$V^{0}_{Rk,s,l,y}$	[kN]	17,6	33,7	53,6	65,2
Characteristic spacing of the channel bolts for $V_{Rk,s,l}$	$s_{l,v}$	[mm]	100	100	128	100
Partial factor	$\gamma_{Ms,l}^{1)}$	[-]	1,8			
Steel failure: Connection between channel lips and channel bolt under shear load in direction of the longitudinal axis of the channel for blank channels						
Characteristic resistance	$V^{0}_{Rk,s,l,x}$ [kN]	HBC-T 29/20 M12 8.8F	20,0	-	-	-
		HBC-40/22-N M16 8.8F	-	10,5	-	-
		HBC-50/30-N M16 8.8F	-	-	17,1	17,1
		HBC-50/30-N M20 8.8F	-	-	21,6	21,6
Installation factor	γ_{inst} [-]	HBC-T 29/20 M12 8.8F	1,0	-	-	-
		HBC-40/22-N M16 8.8F	-	1,0	-	-
		HBC-50/30-N M16 8.8F	-	-	1,0	1,0
		HBC-50/30-N M20 8.8F	-	-	1,0	1,0
Steel failure: Connection between channel lips and channel bolt under shear load in direction of the longitudinal axis of the channel for HDG channels						
Characteristic resistance	$V^{0}_{Rk,s,l,x}$ [kN]	HBC-T 29/20 M12 8.8F	14,1	-	-	-
		HBC-40/22-N M16 8.8F	-	8,2	-	-
		HBC-50/30-N M16 8.8F	-	-	13,6	13,6
		HBC-50/30-N M20 8.8F	-	-	15,9	15,9
Installation factor	γ_{inst} [-]	HBC-T 29/20 M12 8.8F	1,0	-	-	-
		HBC-40/22-N M16 8.8F	-	1,4	-	-
		HBC-50/30-N M16 8.8F	-	-	1,2	1,2
		HBC-50/30-N M20 8.8F	-	-	1,0	1,0

¹⁾ In absence of other national regulations

Mounting channels (PEC-M) with channel bolts (HBC)

Performance Data

Characteristic resistances of mounting channels under shear load

Annex C2

Table 11: Displacements under shear load of mounting channel

Mounting channel			PEC-MZ 29/20	PEC-M 40/22	PEC-M 50/30	PEC-M 52/34
Shear load	V_y	[kN]	7,9	12,7	27,8	27,3
Short-term displacement ¹⁾	$\delta_{V0,y}$	[mm]	1,1	2,8	3,4	3,9
Long-term displacement ¹⁾	$\delta_{V\infty,y}$	[mm]	1,6	4,2	5,1	5,8
Shear load	V_x	[kN]	4,9	4,8	7,4	-
Short-term displacement ¹⁾	$\delta_{V0,x}$	[mm]	0,3	0,6	0,5	-
Long-term displacement ¹⁾	$\delta_{V\infty,x}$	[mm]	0,6	0,8	0,8	-

¹⁾ Displacements in midspan of the mounting channel, including slip of channel bolt and deformation of channel lips

Table 12: Characteristic resistances under combined tension and shear load of mounting channel

Mounting channel			PEC-MZ 29/20	PEC-M 40/22	PEC-M 50/30	PEC-M 52/34
Steel failure: Local flexure of channel lips and flexure of channel						
Product factor	k_{13}	[-]	Values according to EN 1992-4:2018, Section 7.4.3.1			

Mounting channels (PEC-M) with channel bolts (HBC)

Performance Data

Displacements under shear load and characteristic resistances under combined tension and shear load

Annex C3

Table 13: Characteristic resistances under tension and shear load – steel failure of channel bolts

Channel bolt				M10	M12	M16	M20		
Steel failure									
Characteristic resistance (tension load)	$N_{Rk,s}$	[kN]	HBC-T 29/20	8.8	1)	67,4	1)	1)	
			HBC-40/22	4.6	23,2	1)			
				8.8	1)	67,4	125,6	1)	
				A4-70 2)	40,6	59,0	109,1		
			HBC-40/22-N	8.8	1)		125,6	1)	
			HBC-50/30	4.6	1)				
				8.8	1)	67,4	125,6	129,2	
				A4-70 2)		59,0	109,1	121,2	
			HBC-50/30-N	8.8	1)		125,6	129,2	
			Partial factor	$\gamma_{Ms}^{3)}$	[-]	HBC-T 29/20	4.6	2,00	
HBC-40/22(-N)	8.8	1,50							
HBC-50/30(-N)	A4-70 2)	1,87							
Characteristic resistance (shear load)	$V_{Rk,s}$	[kN]	HBC-T 29/20	8.8	1)	33,7	1)	1)	
			HBC-40/22	4.6	13,9	1)			
				8.8	23,2	33,7	62,8	1)	
				A4-70 2)	24,4	35,4	65,9		
			HBC-40/22-N	8.8	1)		62,8	1)	
			HBC-50/30	4.6	1)				
				8.8	1)	33,7	62,8	98,0	
				A4-70 2)		35,4	65,9	102,9	
			HBC-50/30-N	8.8	1)		62,8	98,0	
			Partial factor	$\gamma_{Ms}^{3)}$	[-]	HBC-T 29/20	4.6	1,67	
HBC-40/22(-N)	8.8	1,25							
HBC-50/30(-N)	A4-70	1,56							

Mounting channels (PEC-M) with channel bolts (HBC)

Performance Data

Characteristic resistance of channel bolts under tension and shear load

Annex C4

Table 14: Characteristic resistances under shear load with lever arm – steel failure of channel bolts

Channel bolt				M10	M12	M16	M20	
Steel failure								
Characteristic flexural resistance	$M^0_{Rk,s}$ ⁵⁾	[Nm]	HBC-T 29/20	4.6	29,9 ²⁾	3)		
			HBC-40/22(-N)	8.8	59,8	104,8	266,4	519,3
			HBC-50/30(-N)	A4-70 ²⁾	52,3	91,7	233,1	3)
Partial factor	γ_{Ms} ¹⁾	[-]	HBC-T 29/20	4.6	1,67			
			HBC-40/22(-N)	8.8	1,25			
			HBC-50/30(-N)	A4-70 ²⁾	1,56			
Internal lever arm	a	[mm]	HBC-T 29/29	3)	17,0	3)		
			HBC-40/22(-N)	24,3	25,7	27,3	3)	
			HBC-50/30(-N)	3)	29,9	31,7	33,9	

1) In absence of other national regulations

2) Materials according to Table 4, Annex A5

3) Product not available

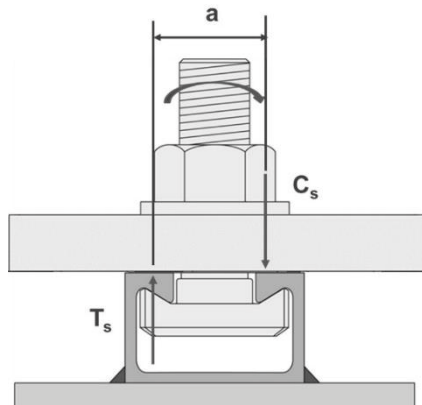

5) The characteristic flexure resistance according to Table 14 is limited as follows:

$$M^0_{Rk,s} \leq 0,5 \cdot N_{Rk,s,l} \cdot a \quad (N^0_{Rk,s,l} \text{ according to Table 8})$$

$$M^0_{Rk,s} \leq 0,5 \cdot N_{Rk,s} \cdot a \quad (N_{Rk,s} \text{ according to Table 13})$$

a = internal lever arm according to Table 14

T_s = tension force acting on the channel lip

C_s = compression force acting on the channel lip

Mounting channels (PEC-M) with channel bolts (HBC)

Performances

Characteristic resistances of channel bolts under tension and shear load
 Characteristic flexural resistances of channel bolts under shear load

Annex C5

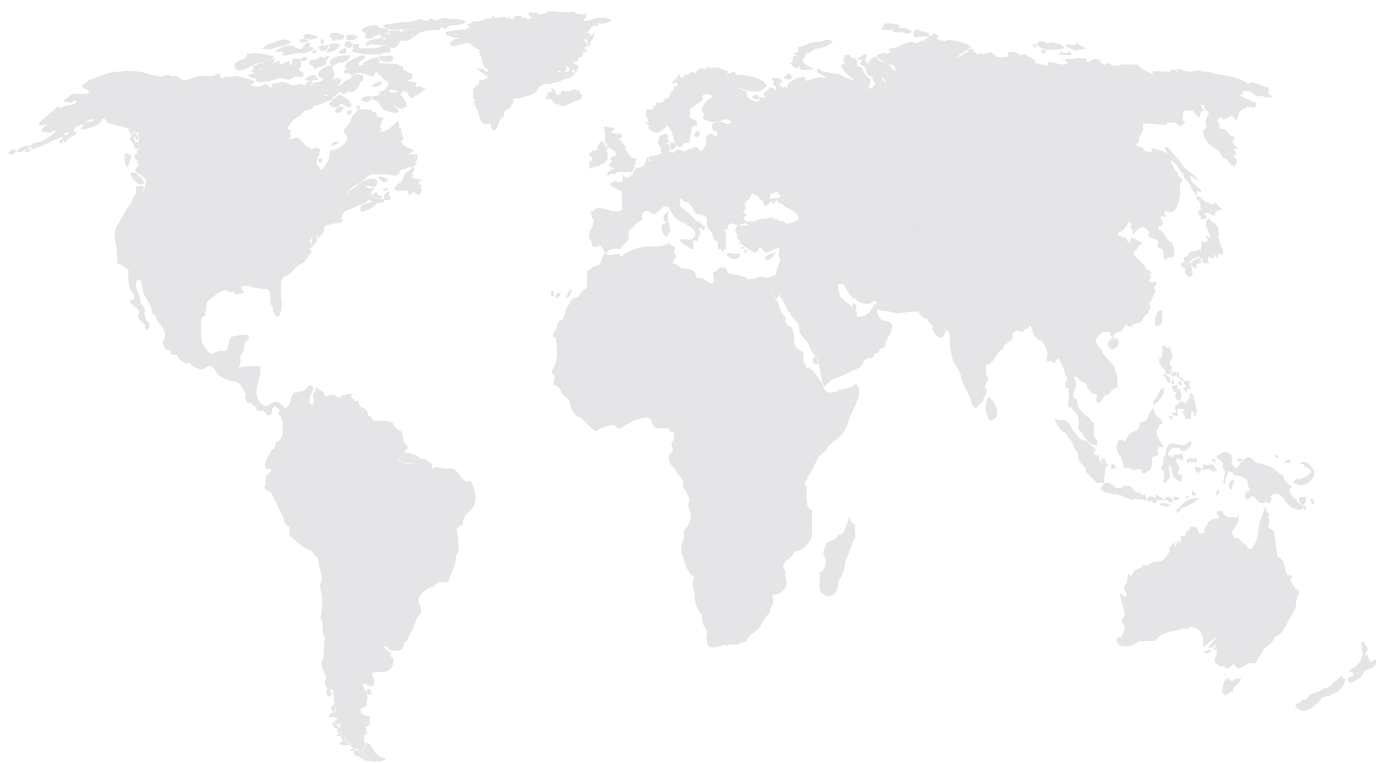

www.pec-europe.com

PEC Europe GmbH

Obere Kaiserswerther Straße 56
47249 Duisburg / Germany
Telefon: +49 (0) 203 - 45 65 99 0
Fax: +49 (0) 203 - 45 65 99 25
sales@pec-europe.com

pec EUROPE
*The best of
both worlds!*

Weitere Informationen finden Sie auf unserer Webseite unter www.pec-europe.com.